



# MODERN PENTATHLON 2017 EQUIPMENT REGULATIONS

## 1. General Aspects

This document is in addition to UIPM Modern Pentathlon 2017 Competition Rules. Separate Technical Equipment Regulations are more practical and can respond to necessary innovation or safety updates regarding equipment.

## 2. FENCING

### Part A INDIVIDUAL EQUIPMENT

#### 2.1 CLOTHING

- 1 General aspects
- 2 The Jacket
- 3 Breeches and Socks
- 4 The Glove

#### 2.2 THE EQUIPMENT

- 1 The Mask
- 2 The Epée
- 3 The Bodywire

### Part B EQUIPMENT PROVIDED BY THE LOC

#### 2.3 FOP AND PISTE

- 1 The FOP
- 2 The Piste

#### 2.4 OTHER EQUIPMENT

- 1 Scoring Apparatus
- 2 Spools

#### 2.5 THE LOC CONTROL DEVICES AND TOOLS

- 1 Gauges for Physical Dimensions of Weapons
- 2 Devices for Flexibility of Blades and Resistance of the Mesh
- 3 Electrical Checking Device
- 4 Weights
- 5 Devices for Point Travels
- 6 Labels
- 7 Special Ink or Paint
- 8 Other Equipment and Tools
- 9 Bonus Round



# UIPM

Union Internationale  
de Pentathlon Moderne



## Figures

Figure 1	Design of Fencing Piste
Figure 2	Standard Piste
Figure 4	Epée Dimensions and Flexibility
Figure 5	Epée: design of point d'arrêt and tip of Point
Figure 6	Shape of a Non-orthopedic Grip
Figure 7	Gauge for Checking Weapons
Figure 8	Weight to Check Pressure
Figure 9	Checking Point travel



## **PART A INDIVIDUAL EQUIPMENT**

### **2.1 CLOTHING**

#### **2.1.1 General Aspects**

- i) The clothing must provide the competitor with the maximum protection compatible with the freedom of movement necessary for fencing. Clothing must be made of sufficiently robust material and be clean and in good condition.
- ii) The material from which the equipment is made must not have a surface that is smooth enough to cause the point d'arrêt, the button or the opponent's hit to glance off it.
- iii) Clothing must be made entirely of material able to resist a pressure of 800 Newtons. Very particular attention must be paid to ventilation access under the armpits, if any is made.
- iv) An undergarment consisting of protective under-plastron covering the vital upper areas of the body resistant to 800 Newtons is also obligatory.
- v) Clothing may be of different colours, but on the body must be a single colour, white or a light shade.
- vi) A homologation mark must appear on blades, under plastron, jackets, breeches, masks, and include the identification of the manufacturer, the date of manufacturing and the FIE or UIPM logo.
- vii) The most recent version of list with homologated equipment is valid.
- viii) No jewellery or any visible body piercing is permitted. Athletes must remove or cover these items in a safe way
- ix) Hair must be secured in a way so as not to cover the name printed on the Fencing jacket or start number.

#### **2.1.2 The Jacket**

- i) The lower edge of jacket must overlap the breeches by at least 10cm when the pentathlete is in the on-guard position. The jacket must include a lining making a double thickness of material for the sleeve down to the elbow of the sword arm and covering the flank up to the region of the armpit.
- ii) The equipment of female pentathletes must include breast protectors made of a rigid material or metal.
- iii) Pentathletes must wear their surname and National code letters (Latin characters) on the back of their fencing jacket in clearly legible text either black or dark blue capital letters. The letters must be printed or embroidered and must be between 7 - 12cm high. Failure to do so will incur a penalty according to Rule 2.6.3 v).
- iv) The pentathletes must wear on the non-sword arm, between the elbow and the shoulder, a 7-10 cm armband in the national colours or strip in national colours on their sleeve. Failure to do so will incur a penalty according to Rule 2.6.3 v).

#### **2.1.3 Breeches and Socks**

- i) Breeches must be fastened below the knees. With breeches, the pentathlete must wear socks that cover the legs right up to breeches. These socks must be held up in such a way that they cannot fall down.
- ii) A pentathlete is permitted to wear socks with a turnover showing the colours of their national team 10 cm high.

#### **2.1.4 The Glove**

- i) The gauntlet of the glove must, in all circumstances, fully cover approximately half the forearm of the pentathlete's sword arm to prevent the opponent's blade entering the sleeve of the jacket.
- ii) The glove on the gauntlet must not be covered by material that can cause the point to glance off.

### **2.2 EQUIPMENT**

#### **2.2.1 The Mask**



- i) The mask must be made with mesh (space between wires) of maximum 2.1mm and from wires with a minimum gauge of 1mm diameter.
- ii) The mesh must withstand, without permanent deformation, the introduction into the mesh of a conical instrument, the angle of the surface of the cone being at 4° to the axis and a pressure of 12kg.
- iii) The bib of the mask must be made with cloth resistant to 1600 Newtons. Only masks with two independent security devices will be allowed for use at all UIPM competitions. The mask must not be covered, in whole or in part, by material that can cause the point to glance off it. The mask must be so shaped that the bib reaches below the prominence of the collarbones (clavicles).
- iv) A mask which does not comply with the safety requirements laid down in this article will be visibly rendered unusable by the weapon checking personnel.

## 2.2.2 The Epée

- i) **Weight and length**
  - a) The total weight of the épée ready for use must be less than 770 grams.
  - b) The total maximum length of the épée is 110 cm.
- ii) **The Blade**
  - a) The blade, which is triangular in section, without cutting edges, is made of steel and must be complying with safety standards
  - b) There are two methods of manufacture (see Figure 4):
    - 1) By forging a steel cylinder (Cross – section of blade, A);
    - 2) By folding a sheet of steel (Cross – section of blade, B).
  - c) It should be straight as possible and be mounted with the groove uppermost. Any curve of the blade must be uniform and the maximum bend must in any case be less than 1cm; it is only permitted in the vertical plane and must be near to the centre of the blade.
  - d) The maximum length of the blade is 90 cm and the maximum width of any of the 3 sides of the blade is 24 mm.
  - e) The blade must have a flexibility equivalent to a bend of 4.5 cm minimum and 7 cm maximum, measured in the following way:
    - 1) The blade is fixed horizontally at a point 70 cm from the extremity of the button.
    - 2) A 200grams weight is suspended 3 cm from the extremity of the button.
    - 3) The bend of the blade is measured at the extremity of the button between the non-weighted and the weighted position (See Figure 4).
  - f) Treating a blade between the guard and the tip (button) by grinding, filling or other methods, is forbidden. Sharpening the edges or angles of the point is forbidden.
  - g) At UIPM Category “A” competitions, all individual equipment must fulfil the FIE competition requirements. Only FIE homologated maraging blades are permitted.  
Note: N = non-maraging steel; and are not allowed at UIPM Category “A” competitions.
  - h) Fencing in other UIPM competitions non-maraging steel blades are allowed, but must comply with current safety standards.
- iii) **The Electric Wires**

The épée has 2 electrical wires, glued in a groove in the blade, which connect the button of 2 of the 3 sockets situated inside the guard and which forms the active circuit of the épée. The body of the épée is connected to the third socket.
- iv) **The Guard**
  - a) The convex face of the guard must be of a shape and surface that is both smooth and not too bright. It must be made in such a way that it can neither hold nor catch the opponent’s point. It must not have a raised rim. The guard, which must have a circular edge, must be able to pass through a cylindrical gauge having a diameter of 13.5 cm and a cylindrical length of 15 cm, the blade being parallel to the axis of the cylinder. The depth of the guard (the distance between lines ‘b’ and ‘c’) must be between 3 and 5.5 cm.
  - b) The total length between lines ‘a’ and ‘c’ must never be greater than 95.5 cm. Eccentric mounting is allowed provided the distance between the centre of the guard and the point where the blade passes the guard does not exceed 3.5 cm.



- c) Inside the guard there must be a cushion (padding) of sufficient width to protect the electric wires from the pentathlete's fingers. The padding on the inside of the guard must be less than 2 cm thick and must be arranged so as not to increase the protection that the guard affords the hand. The connections must be so arranged that it is impossible for the pentathlete to break or make contacts while fencing.
- d) The two wires must be protected by insulating sheaths, one on each wire. Both the wire and insulating sheaths must go right up to the socket. In no case may non-insulated wires project beyond the point where they are attached to the socket.
- e) Any system of attachment inside the guard is allowed, provided that it conforms to the following requirements:
  - 1) It must be easy to detach or attach the body wire;
  - 2) it must be possible to check it by a simple method such as using a penknife or a knife;
  - 3) it must be easy to apply the point d'arrêt of the opponent's weapon to the earth circuit connected to the blade;
  - 4) it must have a security device, which makes it impossible for the contact to be broken during the bout;
  - 5) it must ensure the complete connection of the electric wires; it must be impossible for even a momentary break of contact to occur while the plugs are connected;
  - 6) it must not include any part that allows electrical contact to be made between the plug sockets.
- f) The maximum electrical resistance allowed on épée is 2 ohms.
- g) Those who wish to assemble electric weapons, but who are not equipped to undertake electrical tests, are advised that the limits for the electrical resistance for the circuits laid down for each weapon have been fixed so that they can be attained by anyone who is reasonably careful. They are advised:
  - 1) thoroughly to de-oxidise the external surface of the guard and the connecting surfaces inside it;
  - 2) not to destroy the insulation of the wires, especially where they pass along the groove in the blade at the point and at the guard;
  - 3) to avoid accumulations of glue in the groove of the blade.
- v) **The Pointe d'Arrêt and the Button**

The electric button is completed by a pointe d'arrêt that must conform to current standards. Only traditional or homologated pointes d'arrêt are accepted. No other kind of pointe d'arrêt, notably new ones that are not homologated, will be accepted.
- vi) **Fixing the Button**

The base of the button may be made in one piece with the blade or the flattened piece of the tip of the blade retained. The button must be screwed onto the end of the blade, which must be cut and threaded for this purpose, under the following conditions:

  - a) Normally, only fixing by metal-to-metal to the end of the blade is allowed. Fixing by insulating material is forbidden.
  - b) Any method of soldering or brazing or any heating in general that may affect the temper of the blade is forbidden. Only a solder of very easily melted tin used with a soldering iron to prevent the tip from coming loose is authorised.
  - c) The end of the blade before cutting the thread must not have a diameter at any point of less than 4mm, and this without anything being wrapped around it, a process which is strictly forbidden.
  - d) The diameter of the core of the thread must not be less than 3.05 mm (thread SI. 4.0 x 0.70).
- vii) **The Grip**
  - a) The maximum length of the épée's grip is 20 cm, measured between lanes 'b' and 'e', and 18 cm between the lanes 'b' and 'd' (See Figure 4).
  - b) The grip must be able to pass through the same gauge as the guard. It must be made in such a way that it normally cannot injure either the user or his opponent. All types of grips are allowed providing that they conform to the rules, which have been framed with a view to placing the various types of weapons on the same footing. Orthopaedic grips, whether metal or not, may not be covered by leather or any material which could hide wires or switches.



- c) The grip must not include any device that assists the pentathlete to use it as a throwing weapon. The grip must not include any device that can increase in any way the protection afforded to the hand or wrist of the pentathlete by the guard. A cross bar or electric socket that extends beyond the edge of guard is expressly forbidden.
- d) If the grip (or glove) includes any device or attachment or has a special shape (orthopaedic) that fixes the position of the hand on the grip, the grip must determine and fix one position only for the hand and grip. When the hand occupies this position on the grip, the extremity of the thumb when completely extended must not be more than 2 cm from the inner surface of the guard. It is forbidden to have devices that attach the grip to the hand since this would result in extra strength and possible risk of injury to the opponent. The use of grips such as the gardère or other similar grips is forbidden, provided that this rule does not prohibit the use of the grip conventionally known as the orthopaedic grip.

### 2.2.3 The Bodywire

- i) The conductive wires of the body wire as part of the pentathlete's personal equipment must be well insulated from each other, insensitive to humidity and either joined or twisted together. The maximum electrical resistance allowed for each of these conductive wires from plug to plug is 1 ohm.
- ii) The body wire must have a connecting plug on each end. At the spool end, a three pin male plug must be connected to the wire as follows:
  - a) The pin 15 mm from the centre pin to whichever wire is most directly connected to the point d'arrêt;
  - b) The centre pin to the other wire of the épée;
  - c) The pin 20 mm from the central pin to the épée's earth circuit and to the conductive piste.

## **B EQUIPMENT AND FACILITIES PROVIDED BY THE LOC**

### 2.3 FOP AND PISTE

#### 2.3.1 The FOP

The field of play should have an even surface. It should give neither advantage nor disadvantage to any pentathlete, especially as regards to lighting. The fencing area inside the FOP must be restricted only to the pentathletes and judges.

#### 2.3.2 The Piste

That portion of the field of play which is using for fencing is called **the piste** (See Figures 1 and 2).

- i) There should desirably be a sufficient number of pistes to run the events with the athletes/teams/groups paired. The pistes are lettered starting in A and placed in the FOP in such a way that the teams, after each round, will change to the neighbouring piste. One reserve piste must be provided.
- ii) A conductive piste must be made from metal, metallic mesh or some substance with a base that is conductive.
  - a) The resistance of the piste, from one end to the other, must not exceed 5 ohms.
  - b) The piste is from 1.50 metres to 2.00 metres wide.
  - c) The piste is 14 metres long, so that each pentathlete being placed at 2 metres from the centre line has at his disposal for retreating a total distance of 5 metres without it being necessary for him to cross the rear limit of the piste with both feet.
- iii) **Five lines** should be drawn very clearly on the piste at right angles to it its length, as follows:
  - a) One centre line that must be drawn as a broken line across the whole width of the piste;
  - b) two on-guard lines at 2 metres on each side of the centre line. These must be drawn across the whole width of the piste;
  - c) two lines at the rear limits of the piste, which must be drawn across the whole width of the piste, at a distance of 7 metres from the centre line. In addition, the last 2 metres of the piste before these rear limit lines must be clearly distinguished.



- d) If possible by a different colour of piste – to make it easy for the pentathletes to be aware of their position on the piste.
- e) If the last 2 metres of the piste is the same colour, the last 2 m must be clearly marked alongside of the piste with a different colour to the floor.
- iv) The conductive piste must cover the whole length and breadth of the piste including its extensions. When the piste is mounted on a platform the conductive piste must cover the whole width of the platform. The platform must not exceed 50 cm height and must be wider than the fencing piste itself by at least 25 cm on each side. Each end of the podium must be equipped with a gentle slope down to the ground level.
  - a) An extension of 1.50 metres to 2 metres is added at each end of the piste on which the pentathletes can retire. The conductive piste must therefore have a total length of 17 to 18 metres.
  - b) The paint used to draw the lines on the conductive piste must not prevent its electrical conductivity so that a hit made on it where a line occurs is also neutralised.
  - c) The Organising Committee must have equipment available on the spot for the immediate repair of the piste.
  - d) There must be no roller or any sort obstacle at the ends of the conductive piste, which could prevent the pentathletes from retreating normally.
  - e) The table or support on which the judging apparatus is placed should stand opposite the central lane and at least 1 metre from the piste.
  - f) One or more pistes must be available as reserve pistes to be used when one or more matches are slower than the rest.

## 2.4 OTHER EQUIPMENT

### 2.4.1 Scoring Apparatus

- i) There must be one **central judging apparatus** with extension lamps for each piste.
  - a) Only an electrical apparatus designed with wires connecting the pentathletes to the central apparatus and registering hits by a light signal with auxiliary sound signals are authorised. The apparatus registers when contact is established between the wires forming the circuit in the épée, thus completing the circuit.
  - b) The apparatus must register only the first hit that is made. In case the interval of time between 2 hits is less than 40 milliseconds (1/25 of a second), the apparatus must register a double-hit. Then both signal lamps must light up simultaneously. When the interval is greater than 50 milliseconds (1/20 seconds) the apparatus must register only one hit. Then only one signal lamp is lit. The tolerance allowed for timing the apparatus is that between these two limits (1/25 seconds and 1/20 seconds).
  - c) When the external resistance is normal, that is 10 ohms, the apparatus must register hits when these are made with duration of contact of 2 - 10 milliseconds. With one exceptional external resistance of 100 ohms the apparatus must still register a hit, but without any specific duration of contact.
  - d) The apparatus must not register hits that are made on the earthed material (on the guard or on the conductive piste), even when there is a resistance of 100 ohms in the earth circuit. The apparatus must not register a hit made in the metallic piste or on the metallic parts of the weapon, nor may it prevent the registering of a hit made simultaneously by the opponent.
- ii) The apparatus must be based on an **electrical supply** of 12 volts. The electrical connection on the apparatus provided to connect it to the supply must be so constructed that it is impossible to connect the apparatus by mistake to the general supply (mains). If the apparatus is constructed for use with dry batteries, it must be equipped with a voltmeter or other device whereby the state of the dry batteries can be checked at any time. Nevertheless, the apparatus must always be provided with the electrical connection prescribed above to enable it to be supplied by batteries.
- iii) The apparatus must include a **warning light** to indicate that the apparatus is under tension and this lamp should be colourless.
- iv) **Visual signals** include at least 2 signal lamps on each side of the apparatus, so designed that if one lamp does not function it does not prevent the other from lighting up nor cause an excessive current through the latter. The signal lamps should give a red signal on one side of the apparatus and a green signal on the other. The apparatus may



include lights that indicate shorts to the earthed circuit; these should be orange in colour. The light bulbs, which show when hits are registered, are usually covered with translucent shades. It must, however, be possible to remove these shades and use the naked lights when the lighting conditions in the locality make it desirable to do so (strong sunlight or, exceptionally, in the open air).

- a) The signal lamps must be placed on top of the apparatus in order that they may be simultaneously visible to the Referee on the piste, the pentathletes and the superintendent of the apparatus. They must be so positioned that they show clearly from which side the hit was made. Arrangements must be made so that extension lamps can be added to the exterior of the apparatus in order to increase the visibility of the signals.
- b) However, should there be a difference between the signals given by the lamps on the apparatus and those given by the extension lamps, the signals by the apparatus are decisive.
- c) Once the signal lamps are alight they must remain so until the apparatus is reset, without having any tendency to go out or to flicker either when subsequent hits are made or if the apparatus is subjected to vibrations.
- v) The visual signals must be accompanied by an **audible sound**. For this the apparatus must have a loud sound signal. The resetting switches must be placed either on top of or in front of the apparatus. The apparatus may include a device which allows the sound signal to be stopped before the apparatus is reset.
- vi) There must be a source of electrical current (batteries) for each apparatus, and a sufficient number of batteries in reserve.

#### 2.4.2 Spools

- i) At official UIPM Category "A" competitions at least **2 spools** with complete cables and connections for each apparatus must be provided at each end of the pistes. This is also recommended for other official UIPM competitions.
- ii) The maximum electrical resistance of each wire of the spool, measured from socket to socket, must be 3 ohms. There must be no interruption of electrical contact even when the spool is being rotated at full speed. To ensure this, contact rings must have double brushes. The wire connected to the blade of the épée will be connected on the frame of the spool.
- iii) The spools must allow 20m of cable to be unwound without straining the springs.
- iv) The socket which terminates the spool cable, and is designed to receive the plug of the body wire plug at the pentathlete's back, must include a safety device which guarantees that it is impossible to use it unless the plug is correctly put in, that it is impossible for it to become separated during the bout and that it is possible for the pentathlete to verify that the 2 previous requirements are satisfied.
- v) The resistance of each of the 3 wires in the connecting cables must not exceed 2.5 ohms.
- vi) The plugs used to connect the body wire to the spool wire and the connecting cables to the spool and to the apparatus must have 3 pins of 4 mm diameter arranged in a straight line.
- vii) The body wire and the connecting cables must have plugs, the spool wires and the electrical central apparatus must have sockets to them.

#### 2.5 THE LOC CONTROL DEVICES AND TOOLS

The LOC must provide the equipment, devices and tools to check the clothing and equipment of the pentathletes as specified in the following and shown in figures 4, 5, 6, 7, 8 and 9.

2.5.1 **One gauge** allowing measuring the **physical dimensions of the weapons**, lengths of blades and the depths and diameters of the guards at all weapons to be measured quickly.

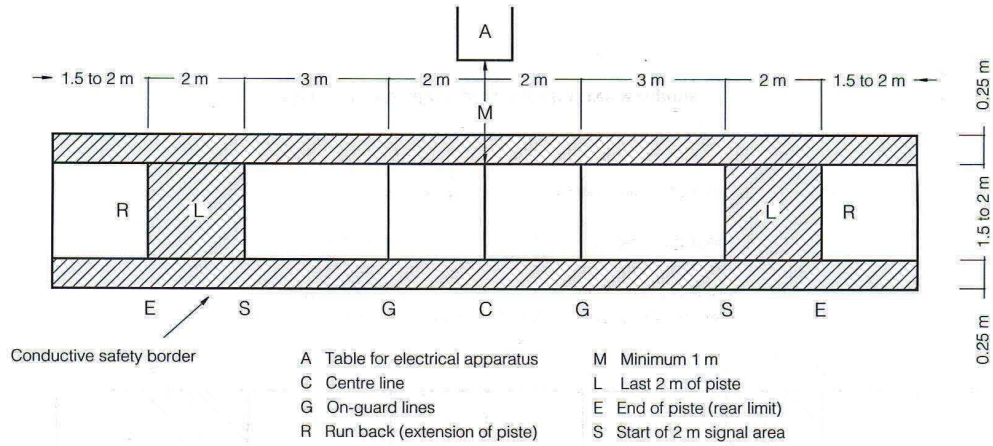
2.5.2 **Devices for** measuring the **flexibility** of blades, the **resistance of the mesh** of masks and the **total height** of the épée.



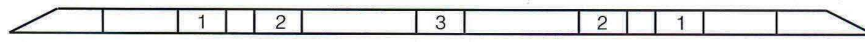
- 2.5.3 An **electrical checking device** to check quickly that the electrical resistance of the point is not too high, and that the bodywire and the weapon are correctly assembled. Devices enabling these measurements to be taken easily are, in fact, commercially available.
- 2.5.4 **Weights** of 750 grams supplied by the LOC to test the pressure of the spring of the points of the épée, in the workshop and at each piste, consists of a metal cylinder drilled part of the way along its axis with a hole parallel to its sides; this hole, into which is inserted the end of the blade, must have an insulating lining to prevent its metallic parts coming into contact with the earthed mass of the épée which might then give a false result to the test. The weight may have a tolerance of  $\pm 3$  g, i.e. 747–753 g.
- 2.5.5 A **device** allowing the lighting stroke and residual **travel of épée points** to be accurately measured, in the workshop and at each piste.
- i) The Referee will check the total travel and the residual travel of the pointe d'arrêt and the pressure of the spring;
  - ii) He will check the total travel by inserting a gauge measuring 1.5 mm between the barrel of the pointe d'arrêt and the tip. This gauge, provided by the Organizing Committee, may have a tolerance of  $\pm 0.05$  mm, i.e. from 1.45 mm to 1.55 mm.
  - iii) He will check the residual travel by inserting a gauge measuring 0.5 mm between the barrel of the pointe d'arrêt and the tip. The apparatus should not register when the point is depressed. This gauge, provided by the Organizing Committee, may have a tolerance of  $\pm 0.05$  mm, i.e. from 0.45 mm to 0.55 mm;
- 2.5.6 **Labels** to indicate that a weapon has been checked and that it satisfies the regulation, or has been rejected.
- 2.5.7 A **special ink or paint** must be provided to mark the guards, blades and points of weapons which have been checked. Nevertheless, those responsible may use other methods to mark the weapons.
- 2.5.8 **Other equipment and tools**  
The LOC must be equipped with the sufficient tools to prepare the pistes, the apparatus and the electric connections. The LOC must also provide tables or supports for the apparatus and 2 chairs in each top of piste.
- 2.5.9 **Fencing Bonus Round**  
Equipment and Facilities provided by the Organiser shall include, at minimum,
- i) one Fencing Piste placed on a platform (see Article 2.3.2)
  - ii) one scoring apparatus with extension lamps (see Article 2.4.1). Additional repeater lights (e.g. on the piste) and screens are recommended to improve spectator view and information. Ideally LED screens are used, displaying in several directions.
  - iii) two spools with complete cables and connections (see Article 2.4.2) for Individual and four spools with complete cables and connections for Relay
  - iv) gauge and test weights (see Article 2.5)
  - v) table for the scoring apparatus
  - vi) enough chairs in the call area for the athletes and two chairs beside the piste for the next competitors
  - vii) two chairs for the referee's assistants
  - viii) In case of rain, the Organiser shall arrange provision of coverage for the piste and platform, ideally a clear roof on pillars
  - ix) a warm-up area to allow each pentathlete/team 15 minutes warm-up prior to their bout.



## Figures

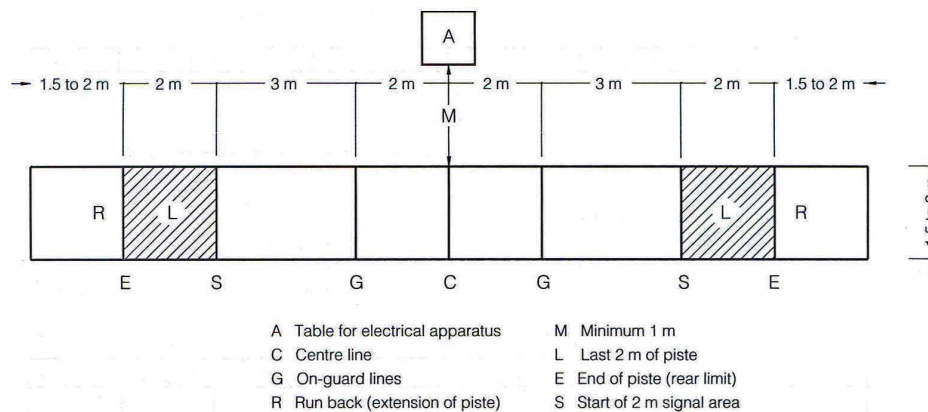


For foil and épée the conductive surface must cover the whole of the length and breadth of the piste, including its extensions (run back) and its safety borders (cf. Article t.13s, m.57)



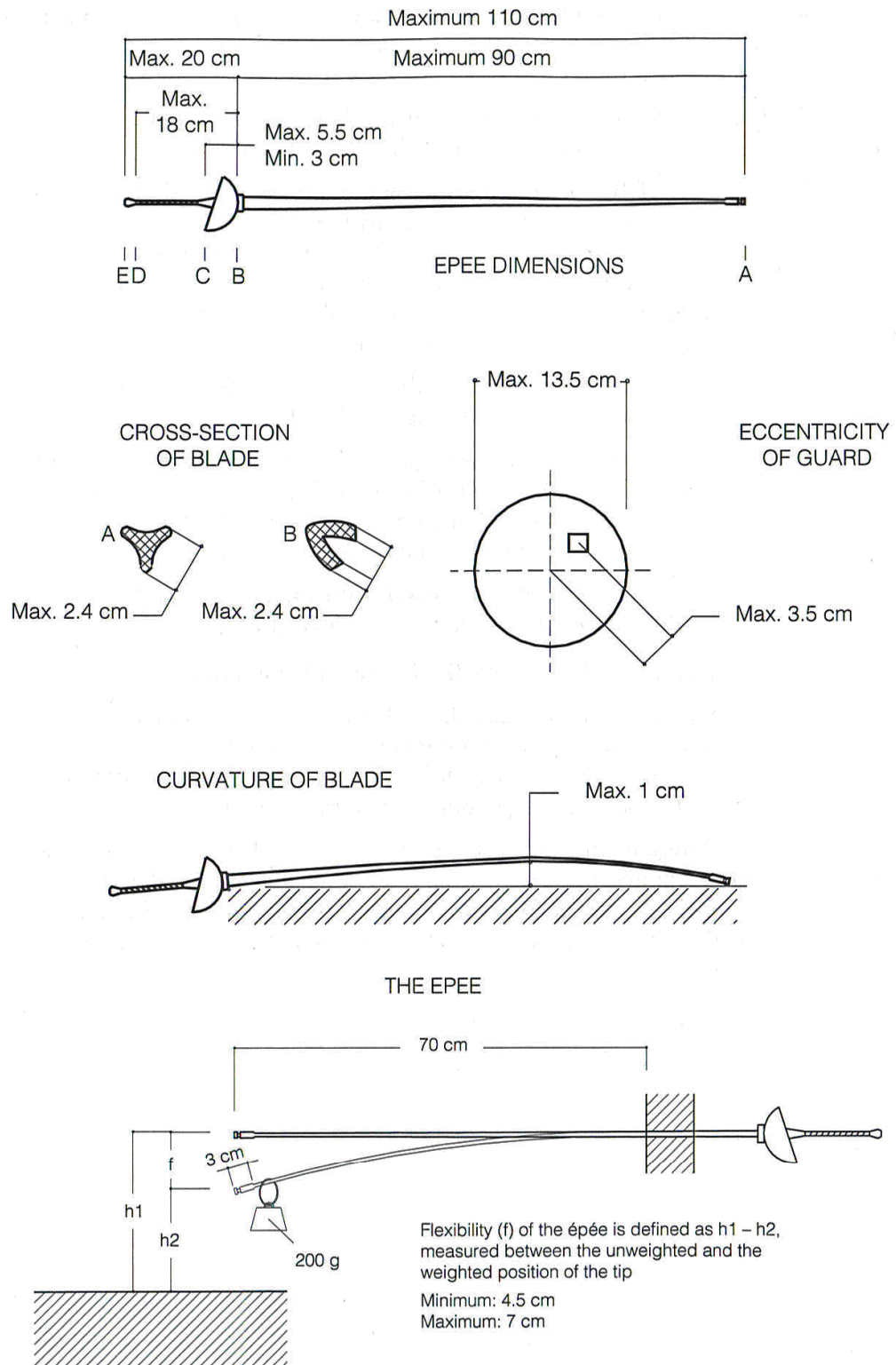
1 Lights registering hits 2 Names and nationalities of fencers 3 Clock, score, etc.

Figure 1. Piste for semi-finals and finals (maximum height 50 cm)

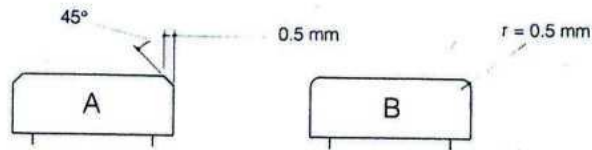


For foil and épée the conductive surface must cover the whole of the length and breadth of the piste, including its extensions (run back) (cf. Article t.13s, m.57)

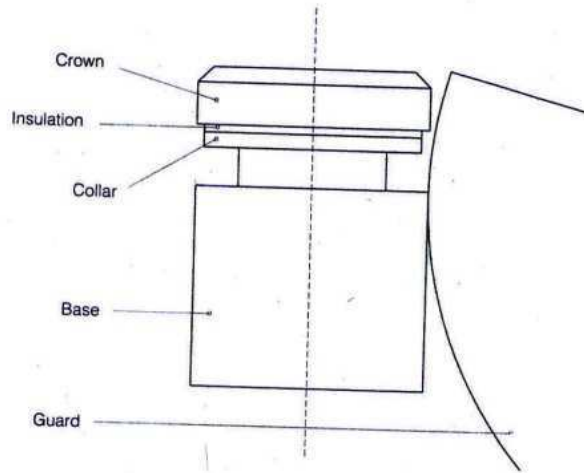
Figure 2. Standard piste for all three weapons



**Figure 4. Epée dimensions and flexibility**

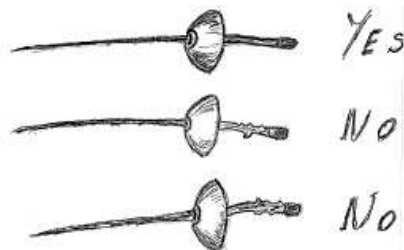


**Epee: design of pointes d'arrêt**



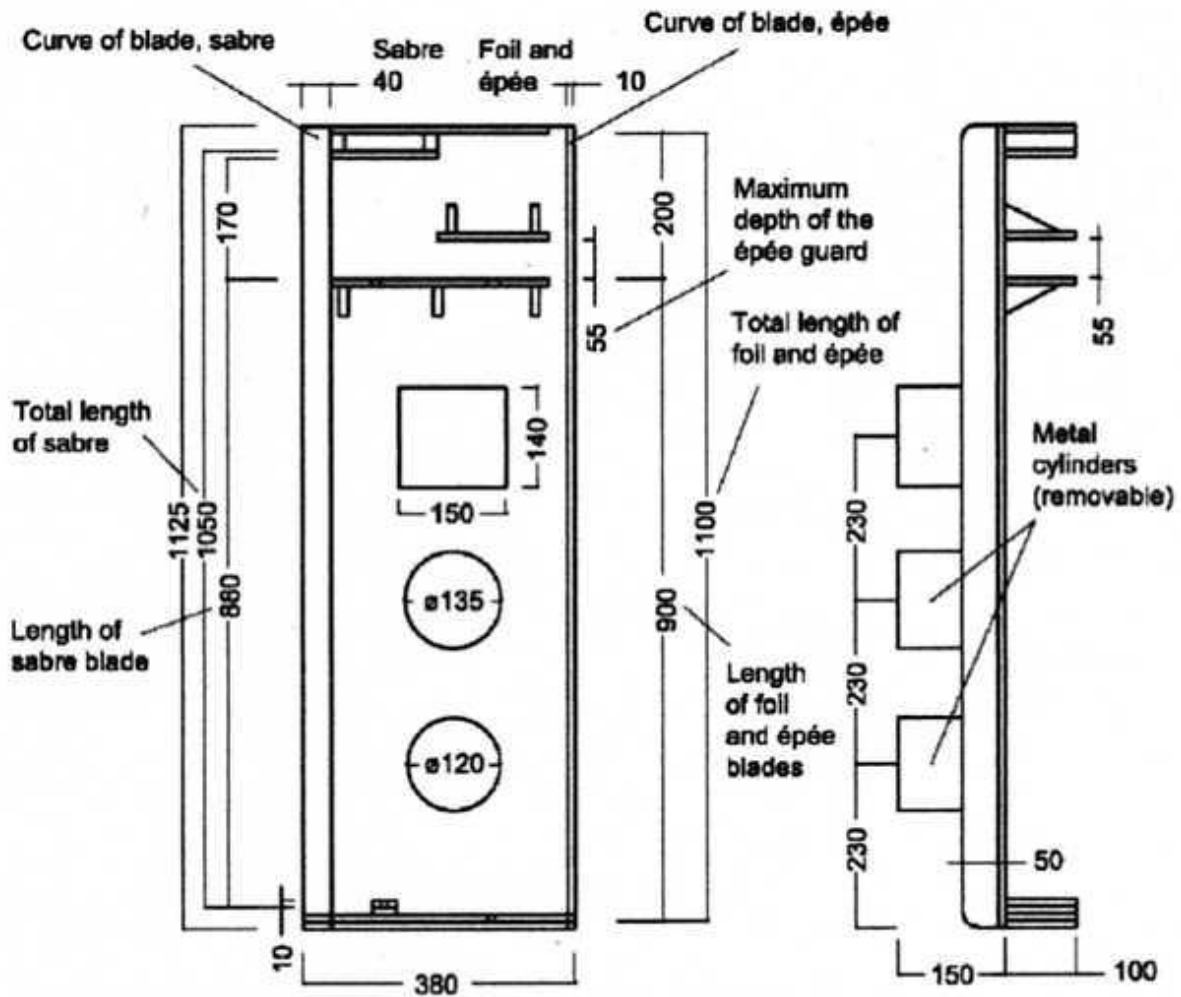
**Epee: details of tip of point**

**Figure 5: The point d'arrêt and the tip of point**



THE GRIP

**Figure 6: Shape of non-orthopedic grip**



Dimensions in mm



Gauge to check the eccentricity of épées  
(Tolerance = 10/12 mm)

Diameter = 135 mm

Figure 7. Gauge for checking weapons

Notes To carry out the checks properly and rapidly, 'workshop' teams of three people should be used. (At least two such workshops should be provided.)

1. The first person checks that all the weapons are normal with respect to their dimensions by passing them through a gauge.
2. The second does all electrical tests.
3. The third affixes the checking marks and replaces the weapons in the fencing bag.



Figure 8 - The weight to check the pressure of the spring of the point of the épée

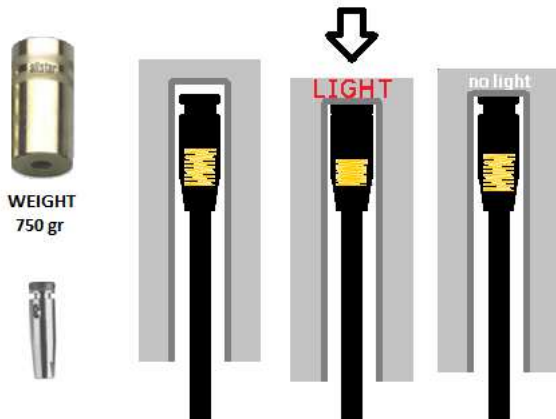


Figure 9b - The Point Travels check

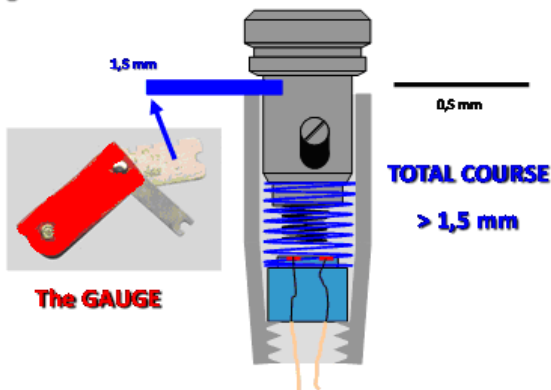


Figure 9a - The Point Travels check

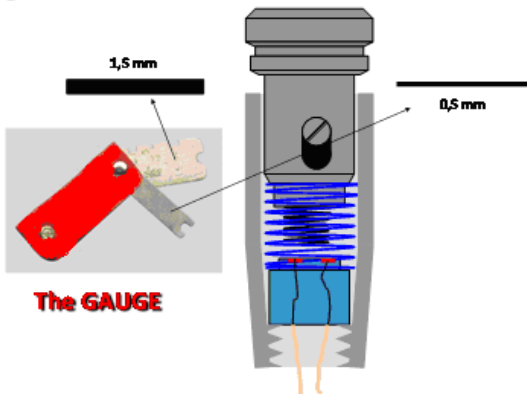
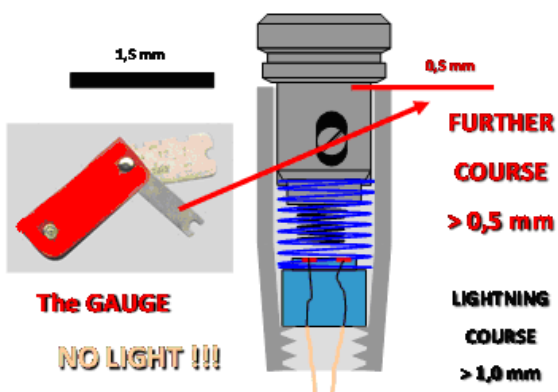


Figure 9c - The Point Travels check





# MODERN PENTATHLON 2017 EQUIPMENT REGULATIONS

## 3. SWIMMING

### PART A      INDIVIDUAL EQUIPMENT

#### 3.7      SWIMWEAR

- 1      **Conditions**
- 2      **Number of Pieces**
- 3      **Dimensions**
- 4      **Devices**
- 5      **Tape**

### PART B      EQUIPMENT PROVIDED BY THE LOC

#### 3.8      THE POOL

- 1      **The Olympic Swimming Pool**
- 2      **Other Pools**
- 3      **Number of Lanes**
- 4      **Starting Blocks**
- 5      **Water Temperature**
- 6      **False Start Rope**



## **PART A INDIVIDUAL EQUIPMENT**

### **3.7 SWIMWEAR**

Only swimwear approved by FINA as set out in its published list of approved swimwear in the preceding and current year may be worn in an UIPM Category A and B official competition.

#### **3.7.1 Conditions**

All pentathletes swimwear must be in good condition and non-transparent.

#### **3.7.2 Number of Pieces**

In swimming competitions, the competitor must wear only one swimsuit in one-piece for male and one or two pieces for female. No additional items, like arm bands or leg bands shall be regarded as part of a swimsuit. No Zipper or other fastening system is allowed.

#### **3.7.3 Dimensions**

Swimwear for men shall not extend above the navel or below the knee, and for women, shall not cover the neck, extend past the shoulder, nor shall extend below knee. All swimsuits shall be made from textile materials.

#### **3.7.4 Devices**

No swimmer shall be permitted to use or wear any device or swimsuit that may aid his/her speed, buoyancy or endurance during a competition (such as webbed gloves, flippers, fins, etc.). Goggles and caps may be worn.

#### **3.7.5 Tape**

Any kind of tape on the body is not permitted unless approved by the UIPM Technical Delegate, or where applicable, the UIPM Medical Director (in accordance with FINA Rules).

## **PART B EQUIPMENT PROVIDED BY LOC**

### **3.8 THE POOL**

A video camera must be provided by the LOC for recording the starts. In case of discrepancy the video decides.

#### **3.8.1 The Olympic Swimming Pool**

At the Olympic Games the pool must be 50m long and a minimum 21m wide. When touch panels for electronic timing equipment are used on the starting end, or additionally on the turning end, the pool must be of such length that it ensures the required distance of 50m between the two panels. Pools must be 1.80m deep throughout.

#### **3.8.2 Other Pools**

At all other official UIPM competitions, pools of 50m, 33m and 25m length may be used upon agreement by the UIPM EB. There must be minimum 1.35m depth at the starting blocks.

#### **3.8.3 Number of Lanes**

- i) The minimum number of lanes in a pool of 50m must be 8. Each must be 2.5m wide with 2 spaces of 50cm width each outside of lanes 1 and 8 respectively.
- ii) Next to each starting block the LOC must provide a box for the athlete to put his clothes before the start.



# UIPM

Union Internationale  
de Pentathlon Moderne



#### 3.8.4 **Starting Blocks**

The height of the starting blocks above the water surface may be from 0.5m to 0.75m. The surface area must be at minimum 0,5m x 0,5m. The surface must be covered with non-slip material. The maximum slope is 10 degrees. The starting blocks must be clearly numbered on all four sides. Lane n°1 is on the right side of the pool, when facing the water from the start top.

#### 3.8.5 **Water Temperature**

The water temperature shall have a temperature of 25-28°C During the competition, the water in the pool must be kept at a constant level, with no noticeable movement.

#### 3.8.6 **False Start Rope**

A false start rope should be hung across the pool not less than 1.20 meters above the water level from fixed points placed 15.00 meters in front of the starting end.



# MODERN PENTATHLON 2017 EQUIPMENT REGULATIONS

## 4. RIDING

### **PART A**      **INDIVIDUAL EQUIPMENT**

#### **4.7**            **CLOTHING**

- 1            **Dress of Pentathletes, coaches and officials**

#### **4.8**            **EQUIPMENT**

- 1            **Headgear**
- 2            **Whip**
- 3            **Use of the Whip**
- 4            **Incorrect Use of the Whip**
- 5            **Spurs**
- 6            **Control of Whip and Spurs**
- 7            **Use of Unauthorized Whip**

### **PART B**      **EQUIPMENT PROVIDED BY THE LOC**

#### **4.09**            **OTHER EQUIPMENT**

- 1            **Obstacles**
- 2            **Flags**

#### **4.10**            **LOC CONTROL DEVICES AND TOOLS**

- 1            **Material**
- 2            **Bell**
- 3            **Balance**



## **PART A INDIVIDUAL EQUIPMENT**

### **4.7 CLOTHING**

#### **4.7.1 Dress of Pentathletes, Coaches and Officials**

Pentathletes, coaches and officials must be properly dressed in the arena. This obligation includes walking the course, but on a non-competition day athletes and coaches are allowed to walk the course dressed in casual clothing (t-shirt and long trousers).

- i) At Olympic Games, World Championships, World Cups and World Cup Finals and Continental Championships all pentathletes must wear a riding jacket or an armed service or police riding uniform with a national insignia (NOC emblem, flag, armlet or badge) of a size between 7 and 10cm high.
- ii) At all other UIPM competitions civilian pentathletes may wear:
  - a) the uniform of a Riding Club recognized by their NF, or
  - b) the hunting uniform (red or black coat, white breeches and hunting cap), or
  - c) Riding Jacket or National Training Suit Jacket, white shirt, collar and tie, breeches, jodhpurs or riding trousers.
- iii) Members of the armed service, police and employees of a military establishment and of a national stud farm may wear civil or service dress. Both must include a shirt, a collar and a tie. NFs must be informed of any restrictions either through the letter of invitation or by UIPM.
- iv) Wearing a back protector (safety vest) for pentathletes is strongly recommended.
- v) The pentathlete is required to use riding boots or chaps with riding shoes. Boots may be made of leather or rubber.
- vi) No jewellery or any visible body piercing is permitted. Athletes must remove or cover these items in a safe way
- vii) Hair must be secured in a way so as not to cover start number.

### **4.8 EQUIPMENT**

#### **4.8.1 Headgear**

- i) All pentathletes must wear protective headgear with chinstrap firmly fastened at all times while mounted - including during the warm up. Should the pentathlete lose their headgear during the course, he must stop and replace his headgear before resuming the event.
- ii) **Riding hat standards.** All riding hats, must conform to current FEI International Standards and bear a homologation mark

#### **4.8.2 Whip**

The maximum length of the whip is 75cm. The whip may not be weighted at the end nor may it have sharp or cutting edges.

#### **4.8.3 Use of the Whip**

The whip may only be used for safety, correction and encouragement. All pentathletes are advised to consider the following good ways of using the whip, which are not exhaustive:

- i) Using the whip in the backhand position for a reminder.
- ii) Having used the whip, giving the horse a chance to respond before using it again.

#### **4.8.4 Incorrect Use of the Whip**

The Referee (in the competition arena) and the Warm-up Riding Judge (in the warm-up arena) are responsible to evaluate the use of the whip. These situations are considered as improper riding, and penalised by 10 Modern Pentathlon points, after or without previous warning. In case of reoffending, Disqualification will be applied. In the case of obvious cruelty or clear disrespect of the procedures described, the athlete will be disqualified without previous warning.

- i) Hitting horses:
  - a) To the extent of causing injury;
  - b) with the whip arm above shoulder height;
  - c) with excessive force;
  - d) without giving the horse time to respond.
- ii) Hitting horses in any place except:
  - a) on the quarters with the whip in either the backhand or forehand position;



- b) down the shoulder with the whip in the backhand position;
- iii) Hitting horses with excessive frequency:  
When examining cases of Excessive Frequency, the Riding Director will consider all the relevant factors such as:
  - a) Whether the number of hits was reasonable and necessary, taking into account the horse's experience;
  - b) whether the horse was continuing to respond;
  - c) the degree of force that was used; the more times a horse has been hit the stricter will be the view taken over the degree of force which is reasonable.

#### 4.8.5 Spurs

- i) The maximum length of the shank of a spur is 30 mm measured from the outside of the curved part. No spurs with rowels, movable wheels, sharp or cutting edges are allowed.
- ii) When the pentathlete is on horseback the spurs shall always point downwards.

#### 4.8.6 Control of Whip and Spurs

Whip and spurs must be controlled by the Judge for Equipment before mounting and immediately before each mounted pentathlete enters the competition arena.

#### 4.8.7 Use of Unauthorised Whip

Using an unauthorised whip or spurs after the control in the arena, warm-up arena or elsewhere in the proximity to the show ground will incur elimination.

### **PART B EQUIPMENT AND FACILITIES PROVIDED BY THE LOC**

#### **4.9 OTHER EQUIPMENT**

##### **4.9.1 Obstacles**

- i) There may be no completely closed obstacles. An obstacle is considered completely closed when a pentathlete jumping its first part cannot leave it without doing a second jump.
- ii) The maximum size of obstacles is:

	<i>Seniors</i>	<i>Juniors</i>	<i>Others</i>
upright obstacle	120cm	110cm	100cm
spread obstacle	120 x 150cm	110 x 130cm	100 x 120cm
oxer (equal bars)	120 x 130cm	110 x 120cm	100 x 110cm

- iii) The obstacles must be numbered consecutively in the order in which they are to be jumped. Combination obstacles carry only a single number. This number may be repeated at each element for the benefit of the Referee and pentathletes. In this case distinguishing letters will be added (example 8A, 8B, 8C).
- iv) Obstacles for the Relay competition are to be chosen from those used in the Individuals competition, but they can be placed in different position in the arena.
- v) The obstacles must be inviting in their overall shape and appearance, varied and match their surroundings. The obstacles and their constituent parts must be such that they can be knocked down while not being so light that they fall at the slightest touch or so heavy that they may cause horses to fall.
- vi) The obstacles must not be un-sporting and they must not cause an unpleasant surprise to foreign pentathletes.
- vii) Poles and other elements of the obstacles are held up by supports (cups). The diameter of the supports must be slightly greater than that of the pole and maximum a third of the circumference, without gripping it. The pole must be able to roll on its support. For planks, balustrades, barriers, gates etc., the diameter of the supports must be more open or even flat.
- viii) FEI approved safety cups must be used as support for the back poles of spread obstacles and in case of a triple-bar to support the centre and back poles of the obstacle. Safety cups must also be used in the exercise area. It is the responsibility of the TD/NTO to establish through the LOC before the event commences whether safety cups are used.



- ix) The limits on the height and spread of obstacles laid down by these rules must be observed with the greatest care. However, if it should happen that a maximum dimension has been marginally exceeded as a result of the material used for construction and/or by the position of the obstacle on the ground, the maximum dimensions laid down will not be considered as having been exceeded, but the permitted tolerance is maximum 5cm.
- x) An obstacle, whatever its construction, can only be called upright when all the elements it is composed of are positioned in the same vertical plane on the take-off side without any rail, bank or ditch in front of it. A wall with an inclined face may not be called an upright obstacle.
- xi) A spread obstacle is an obstacle, which is built in such a manner that it requires an effort both in spread and in height.
- xii) The oxer is a spread obstacle built in such a manner that the top poles on both the take-off and landing sides are the same height and they are parallel.
- xiii) A double or triple combination is understood to be a collection of 2 or 3 elements with distances between them of minimum 7m and maximum 12m that require 2 or 3 successive jumps. The distance is measured from the base of the element on the landing side to the base of the next element on the take-off side.
- xiv) Banks, mounds, ramps and sunken roads, irrespective of whether they include any sort of obstacle and whatever direction in which they should be taken, they are to be regarded as combination obstacles. The UIPM TD/NTO must decide before the competition whether an obstacle of this type is to be considered as a multiple obstacle, and his decision must be shown on the plan of the course.

#### 4.9.2 **Flags**

Entirely red flags (both sides) and entirely white flags (both sides) must be used to mark the following details of the course:

- i) the start;
- ii) the side limits of the obstacles;
- iii) compulsory turning points;
- iv) the finish;
- v) the obstacles in the warm-up arena.

#### 4.10 **LOC CONTROL DEVICES AND TOOLS**

##### 4.10.1 **Material**

The LOC must have disposal of all the material needed to build and rebuild the course and the warm-up obstacles. This includes measure tapes, measure ruler, measure wheel, nails, hammers, tools to repair the ground, hand red flags, the signs "Arena Open" and "Arena Closed", an official clock in the mounting area/warm-up arena, barriers to isolate the unauthorised area, reserves poles and barriers, and so on.

LOC must provide manual stop-watches, draw list, horses list, pens and specific paper to register the results, the results after preceding competitions, material for the draw. The Rule book must also be in the Tower.

##### 4.10.2 **Bell**

For the conduct of the event the LOC must also equip the Judge Tower with a loud bell, preferably electric.

##### 4.10.3 **Balance**

The LOC must have a ruler or other device to check the length of the whip and a device to check the length of the shank of the spurs.



# MODERN PENTATHLON 2017 EQUIPMENT REGULATIONS

## 5. LASER-RUN - RUNNING/SHOOTING

### PART A            INDIVIDUAL EQUIPMENT

#### 5.7            CLOTHING

#### 5.8            EQUIPMENT – THE PISTOL

### PART B            EQUIPMENT PROVIDED BY THE LOC

#### 5.9            THE FOP

- 1            The Venue
- 2            The Different Areas
- 3            The Running Course
- 4            Shooting Range Requirements

#### 5.10           OTHER EQUIPMENT

- 1            Target Requirements
- 2            Laser Hit Target
- 3            Laser Hit/Miss Target
- 4            Laser Precision Target
- 5            Indicators (Result Display Lights)

#### 5.11           LOC CONTROL DEVICES AND TOOLS

### FIGURES

Figure 1 - Indoor or Night Range Light Requirements (in Lux)

Figure 2 – The Pistol Grip

Figure 3 – Bends in the Grip

Figure 4 – The Thumb in the Grip

Figure 8 – Laser Target

Figure 9 – Laser Precision Target

Figure 10 – Indicators (Result Display Lights)

Figure 11 – The Precision Target



## Part A INDIVIDUAL EQUIPMENT

### 5.7 CLOTHING

- i) A pentathlete must wear athletic clothing. In Category A competitions, pentathletes from the same country must wear matching uniform.
- ii) The pentathlete must wear a top with their name clearly visible and professionally made, printed or embroidered, on the back of the top, below which is the NF code, of a size between 7-12 cm and in a contrasting colour to the colour of their shirt.
- iii) Pentathletes must compete with athletic shoes, with or without spikes. Any spike restrictions must be advised by the LOC in their invitation letter.
- iv) The LOC is responsible for providing every pentathlete with two start numbers.
- v) Start numbers, indicating the start order are provided by the LOC in accordance with UIPM Visual Guidelines and must be worn by the athletes. Numbers must be worn on front and back above waist height and be visible in all weather conditions. The start numbers can be made of adhesive material.
- vi) The pentathlete or team who is in first place before the Laser-Run shall be assigned No 1, the second place pentathlete/team, No 2, and so on.
- vii) No pentathlete will be allowed to take part in a competition without appropriate numbers.
- viii) It is forbidden for pentathletes to modify the dimensions (size and width) of the start numbers given by the LOC.
- ix) Wristbands, compressive sleeves, taping or similar items that might provide support to the shooting hand are prohibited on the hand, elbow and arm.
- x) A sports watch is permitted on the non-shooting hand.
- xi) Radios, tape recorders or any type of sound-producing or communication systems are prohibited. Devices whose sole function is noise reduction may be worn.
- xii) It is strongly recommended that current Olympic and World Champions wear clothing, vests or armbands which identify their Champion status to spectators.

### 5.8 THE PISTOL

#### Laser Pistol

- i) Only single shot pistol is allowed without any form of magazine or clip. The shot must be activated by a mechanical trigger (trigger lever movement). Electronical triggers are forbidden but sensors and actuators for activating the emitting of the Laser signal can be used within the pistol
- ii) The single shot laser pistol must be loaded by a loading lever, which needs to be operated by the non-shooting hand. The loading lever must serve the purpose of loading each (laser) shot. The loading lever must be opened mechanically by hand, and with a movement from 0° to a minimum of 35° before the next shot will be enabled.
- iii) The weight of the pistol with all accessories must not exceed 1500 grams. The minimum weight is 800 grams (tolerance 5%), for Under 17 (YB) Youth competitions 500 grams (tolerance 5%).
- iv) The overall size of the complete pistol is limited to dimensions which permit it to be enclosed completely in a rectangular box with inside dimensions of 420mm x 200mm x 50mm. A manufacturing tolerance of + 1.0mm in the dimensions of the box is permitted. The minimum overall size is 20% of the above dimensions (336mm x 160mm x 40mm) with the same tolerance. In each axes the size of the pistol must be greater than or equal to the Minimum-Dimension.
- v) Only open sights are allowed. Optical mirror, telescope, laser-beam, electronic sights, active lights, activated material (other than by ambient light) or electronically projected dot sights are prohibited. Any aiming device programmed to activate the firing mechanism or to give an indication to this is prohibited. No protective covering is permitted on front or rear sights. There must be possibility of vertical and horizontal aiming correction.
- vi) No part of the grip or accessories may encircle the hand. The heel rest must extend at an angle not less than 90° to the grip. Any upward curvature of the heel and/or thumb rests and/or downward curvature of the side opposite the thumb is prohibited (see figure 2). The thumb support must allow the free upward vertical movement of the thumb. However, curved surfaces on the grips or frame, including the heel and/or thumb rest (see figures 3 and 4) in the longitudinal direction of the pistol are permitted.
- vii) Only one (1) laser cartridge/ module per pistol is allowed.



- ix) The laser cartridge must carry the UIPM laser signal of 15.6ms laser signal duration, red colour (635 - 650nm), +/-10nm. The Laser Power must be in the range of 2.5mW – 3.4mW. The barrel time in the range of 6ms and 10ms  
The technical specifications concerning the UIPM Laser signal (shot signal) are given in details in the UIPM document "Technical Specifications Laser Shooting" and in the current UIPM Homologation documents
- x) The following items can be tested at competitions by the Equipment Control Section:
  - a) Weight and overall size of pistol.
  - b) Whether the used Laser modules comply with the specified max./min. Laser power.
  - c) Wavelength of the Laser: 635 to 650nm +/- 10nm;
  - d) The parameters of the embedded and approved UIPM Laser signal, (also called "short Laser signal").
  - e) Beam diameter: max. 6mm at 10 m distance.
  - f) The time the laser beam is released from the pistol, after pushing the trigger, must be between 6ms and 10ms.
  - g) Wire and radio free;
  - h) After approval for the competition the change of any setting for that competition period is blocked.
- xi) Laser security: The used Laser modules comply with Laser class 1 (EN 60825-1:2014/IEC 60825-1:2014, and all updates) in view of the UIPM Laser signal 15.6. The providers are responsible to provide a certificate for each type of the Laser modules they have embedded in their pistols and cartridges intended for the use in Modern Pentathlon.

## **PART B EQUIPMENT AND FACILITIES PROVIDED BY THE LOC**

### **5.9 The Field of Play**

#### **5.9.1 The Venue**

- i) The Laser-Run venue is the site on which the Laser-Run competition is conducted, and consists of the Laser-Run shooting range and the running course. The LOC is responsible for providing a safe and acceptable Laser-Run Course.
- ii) The venue must be technically suitable, according to these rules, to allow all the types of Laser-Run competition to be held. It must offer the best possible viewing of the competitions to spectators, and fulfil all the requirements of TV coverage taking into account protection against sunlight as specified below under Article 5.9.4.i and 5.10.1.viii) in Modern Pentathlon 2017 Competition Rules.

#### **5.9.2 The Different Areas**

- i) There must be the start/finish area, shooting range, last penalties stop area, relay hand-over zone, running course 800m (400m) lap, judges area, coaches area, media and photographers area, spectator areas, as well as buildings and offices necessary for the UIPM and LOC.
- ii) All the areas and most of the running course shall be located on level ground and close together, so as to provide good viewing of competition for the majority of the spectators but without permitting the spectators to access the restricted areas.
- iii) These areas and critical parts of the course must be fenced off in order to prevent pentathletes from being impeded or going off course and to prevent access by unauthorised persons. However, the height and extent of the fencing must be minimised as much as possible to avoid interference to TV coverage.
- iv) There must be sufficient space for pentathletes and competition officials to conduct their required activities and adequate room for team support staff, media, photographers and spectators, and enough space for TV camera crews and their broadcasting facilities without the broadcasting interfering with the competition.
- v) A sheltered area for the pentathletes must be provided by the LOC to protect them from the weather.
- vi) Zones for TV coverage of the competitions will be established on the course, in consultation with the LOC, the UIPM TD/NTO and TV advisor responsible for the event.



The primary purpose of the zones shall be to ensure the best possible coverage of the competition and in particular to prevent obstruction of the TV image by non-competing persons.

- vii) Adjacent to the finish zone, a fenced-off area (Mixed Zone) has to be established for TV company representatives, media and photographers to have close contact with the competitors for interviews and pictures after they finish.
- viii) An exclusive seating area for VIPs and Sponsors must be located by the LOC in the place most appropriate for optimal viewing of the event.
- ix) It is recommended that the LOC provides a separate area close to the Shooting Range with 5 – 6 targets for the athletes.

### 5.9.3 The Running Course

- i) The course must be clearly marked and defined so that a pentathlete is at no time in doubt how to follow the course. The course can be laid out on any kind of surface or surfaces. It must be designed so that there is a minimum risk of injury to the pentathletes without therefore no sharp turns or steep declines.
- ii) The maximum climb of the course is 50 metres.
- iii) The total climb is measured from perpendicular angle from the start area and adding together the total metres of climb from each level.
- iv) The last 50 metres of the course shall be straight and flat and the part of the course from the start line to the shooting place must be large enough to facilitate the start and the approach of the shooting positions.
- v) The course must be marked with a signpost at 400 metres.
- vi) The total course must be wide enough to permit two runners to pass each other at any point on the course.
- vii) The start and finish line must always be in the same area.
- viii) The course must be clearly marked with flags, triangles, barriers, tape etc. and/or marks on the ground so that the direction of the course is always visible for the pentathletes. All angles on the courses in competitions category "A" and "B" have to be marked clearly visible 0.5-1m above the ground, 10m before and 10m after the corner. It is the obligation of the UIPM TD/NTO to check the course.
- ix) The start line and the finish line must be marked by a white line at least 5cm wide on the ground at the place of the start and the finish. It is recommended that a gantry (arch, gate, etc.), vertical poles or something similar also mark the start line and the finish line.
- x) In the Relay competition the start line and the finish line must be a minimum 5m wide. 10m on each side of the finish line must be set for a hand-over zone of 20m length. Thus the dimension of the zone will be 20m x minimum 5m. This zone must be clearly marked by demarcation lines.
- xi) The finish area behind the finish line must be large enough to permit the LOC to take care of the pentathletes having completed the course.
- xii) Access to the finish area with the timing device and timekeepers must be suitably restricted so as not to allow access by pentathletes, media or spectators. Particular attention must be paid to the running shooting zone, to avoid collision between the pentathletes entering the running course after the shooting phase.
- xiii) At all official UIPM Category "A" and "B" competitions a UIPM TD/NTO must inspect and validate the length and path of the course and make changes if necessary. At Olympic Games and World Championships, this inspection must take place at least two days before the start of the competition, in all other competitions, at least one day before the start of the competition.
- xiv) At least 30 minutes before the start, the course must be marked so it is possible to start the warming up.
- xv) At least 5 minutes before the start all necessary restrictions must be settled.

### 5.9.4 Shooting Range Requirements

- i) The range can be indoor or outdoor and must be constructed so that direct sun does not disturb the pentathletes. The targets should be positioned so that the sun does not interfere directly with the registering of shots on the targets. The targets shall be placed 1m +/- 15 cm apart from each other.
- ii) If the venue, the running course and the targets are sufficiently illuminated the Laser-Run can be organized at night. (Figure 1)



- iii) The shooting range must be built in such a way it can guarantee the safety of the pentathletes, coaches, judges and spectators. The firing distance is 10 metres, measured from the firing lane to the target face.  $\pm 0,05\text{m}$  is accepted as tolerance.
- iv) With laser pistols no lateral walls and no back wall are required, but no-access to the range by unapproved people must be in place.
- vi) If the weather forecast is predicted as bad the shooting range must protect the pentathletes from the rain using special roof coverage and a waterproof box to protect the pistols, water, towels and binoculars of the pentathletes located under the shooting table.
- vii) The shooting range must be prepared in such a way the spectators can enjoy the competition and watch the finish, so with the finish line near the shooting range.
- viii) During training, warm up and competition, competitors must enter the range from one side and exit the other side.
- ix) The shooting station must be marked with numbers of a minimum height of 12cm, corresponding to the firing point number. Shooting station nr 1 must be the farthest away from the starting gates.
- x) The pentathlete shooting area (1m +/- 15cm wide x 1.5m deep minimum) must be clearly defined with visible ground painted lateral lines and back line (start line for each running leg). Paint of lateral lines can be replaced by tape or small advertising banner.
- xi) There must be sufficient space (minimum 4m) behind the firing points to allow the pentathletes, before and after each shooting series, to run to their shooting station without disturbing the other pentathletes and to permit the Range Officials and the UIPM TDs/NTOs to perform their duties.
- xii) Targets must be marked with numbers corresponding to their shooting station number. The numbers must have a minimum height of 25cm to be easily seen under normal shooting conditions with normal vision from the appropriate shooting station and from VIP area, public seats and TV cameras.
- xiii) The LOC must guarantee provision of 2 reserve spare targets, numbered S1 and S2. In case of insufficient number of targets for all the pentathletes, the Laser-Run can be organised in two or more series with the top pentathletes competing in the last series.
- xiv) The targets and all the other equipment (target numbers, results display, target covers, lights) must be fixed in such a manner that they have no appreciable movement.
- xv) The height of the target centre must be within the following height measured from level of the floor of the firing point:
  - a) Standard Height Variation: 1.40m +/- 0.05 m
  - b) Horizontal variation: 0.25 m.
- xvi) The firing point must be equipped with:
  - a) a table or bench, about 0.7m – 0.8m high. With laser pistol in the table top there should be a soft pad/foam cushion provided by LOC ( $\pm$  A4 size, 8cm height recommended) to avoid disturbances on the system;
  - b) the table must have a protection for the pistol in case of rain (waterproof box) or a place under the table;
  - c) With LPT the shooting position must be equipped with a transparent table top or with a waterproof transparent plastic box to protect the feedback device.
- xvii) Athletes shall maintain a tidy shooting position with only essential equipment on the table. During the actual competition, the shooting table must be cleared of any other items than the pistol of the athlete and the provided protective pad/foam.
- xviii) With Electronic and Laser targets an adequate uninterrupted power backup system (UPS System) allowing a minimum of 20 minutes run of the system must be provided by LOC in case stadium/arena is not already equipped. The power cable must be 3\*2.5mm 2 section with a waterproof box equipped with a 20A security. This box has to be fixed on the back side of the wall at minimum 0.5m above ground.

## 5.10 OTHER EQUIPMENT

### 5.10.1 Target Requirements

- i) In UIPM Senior A Category competitions laser precision targets are mandatory.
- ii) Only targets homologated by UIPM can be used at Category "A" and "B" competitions and PWR competitions. At the beginning of each season the UIPM publishes a list with the homologation standards, which can be used in Category "A" and "B" competitions.
- iii) In a single Laser target application, the Hit and Hit/Miss targets should be able to operate without any external computer.



- iv) Front target side minimum 170mm \* 170mm. The colour of the target centre zone is black (visible dark from 10m distance). The dimension of this area is 59.5mm, with a tolerance of 0.5mm. Target surface must be white so that the black aiming area (centre) is clearly visible under normal light conditions at the appropriate distances. Targets are compliant with 10m Air Pistol Target draw; See also figures, 5,6 and 8.  
Max input 24V and all standards concerning power over data networks
- v) The valid zone for a "hit" is described, in detail for each target type in detail below.
- vi) The targets must work in all weather conditions including rain and direct sunlight (max30klx).
- vii) Indoor and Night competitions: The LOC must check whether the targets would be interfered by the used artificial lights (Pre-Test of a target in cooperation with UIPM and the provider).
- viii) No active wireless communication by the individual targets in competition mode. For result presentations purposes, the network computer can serve wireless devices. The network computer must be protected against any external communication-interferences.

#### 5.10.2 Laser "HIT" Target (HT)

This kind of targets detects the presence of a Laser signal only in the black zone of the target. Therefore, a feedback arises only with a hit indication.

- i) The technical requirements are:
  - a) The target must identify the approved UIPM Signal Details are specified within the homologation documents..
  - b) 200ms reaction time max concerning internal/external Light interface;
  - c) A shot that hits the black centre zone is a valid shot.(A minimum of 80% of the UIPM signal duration has to be detected).
  - d) Interference from any non-visible light has to be avoided and must be blocked by an IR-filter; Visible light different from the Laser light (wavelength range) should be blocked.
- ii) Specific requirements to all level competitions:
  - a) 1.0mm precision of the laser dot detection at the border line between black and white zone. For a Hit indication, a minimum part of the Laser dot (1mm radius from center point) must be inside of the black aiming area. The valid zone is of diameter 59.5mm (black zone).
  - b) able to be used outdoor.
  - c) external perturbation protected (no reactions caused by incident light, which is different to the UIPM Signal).

Some more details are provided by the technical documents and Homologation documents. ("Technical Specifications Laser Shooting" and the current UIPM Homologation documents),

#### 5.10.3 Laser "HIT/MISS" Target (HMT) (figure 5)

This kind of targets detects the presence of a Laser signal on the target and determines in which zone (black or white), the incident Laser light was detected.

- i) The technical requirements are:
  - a) The target must identify the approved UIPM Signal. Details are specified within the homologation documents.
  - b) 200ms reaction time max concerning Light interface and the data interface (network to the competition server);
  - c) The detection procedure must follow the First-Impact-Detection scheme. A shot that hits the black centre zone first is a valid shot. A shot that hits the white centre zone first is a missed shot.
  - d) able to send data of shots (Hit&Miss results in compliance with the UIPM Open Target Protocol).
  - e) Interference from any non-visible light has to be avoided and must be blocked by an IR-filter; Visible light different from the Laser light (wavelength range) should be blocked.
  - f) Connector for external lights.



- ii) Specific requirements to all level competitions:
  - a) Live display of shots (Hit and Miss) via a data network (UIPM Open Target Protocol).
  - b) Indication of "Hit and Miss" shots on external lights.
  - c) 1.0mm precision of the laser dot detection at the border line between black and white zone. For a Hit indication a minimum part of the Laser dot (1mm radius from centre point) must be inside of the black aiming area. The valid zone is of diameter 59.5mm (black zone).
  - d) able to be used outdoor.
  - e) external perturbation protected (no reactions caused by incident light, which is different to the UIPM Signal).
  - f) competition mode must log all settings and shooting data. All data must be available after the competition for judges' purposes. All targets must have the same behaviour and performance (network management).
  - g) The shooting time starts when the target is hit by the first shot (registered shot, valid or not).

Some more details are provided by the technical documents and Homologation documents. ("Technical Specifications Laser Shooting" and the current UIPM Homologation documents).

#### 5.10.4 Laser Precision Targets (LPT) (see figure 6)

This kind of targets detects the presence of a Laser signal on the target and captures an image of the resulting Laser dot. Image capturing is synchronized with the UIPM-Signal timing. The embedded image processing procedure provides afterwards a precise position information of the dot. Mandatory in Senior A Category competitions.

- i) The technical requirements are:
  - a) The target must identify the approved UIPM Signal and needs synchronization between the Signal and the Laser dot analysis. Details are specified within the homologation documents.
  - b) 200ms reaction time max concerning Light interface and the data interface (network to the competition server).
  - c) The reconstruction procedure must follow the First-Impact-Detection scheme. A shot is valid if after the automatic reconstruction of the calibre 4.5mm from the beam centre impact it hits 7.3 or more. This equals a valid zone of diameter 54.7mm.
  - d) able to send data of shots (X&Y Position of a shot from the impact centre point in compliance with the UIPM Open Target Protocol).
  - e) Interference from any non-visible light has to be avoided and must be blocked by an IR-filter. Visible light different from the Laser light wavelength range should be blocked.
  - f) Connector for external lights.
- ii) Specific requirements to all level competitions:
  - a) Live display of shots on screen in 1/10 units via a data network during warm up (UIPM Open Target Protocol). Result presentations during warm-up by wireless connected devices are recommended.
  - b) Indication of "Hit and Miss" shots on external lights.
  - c) 0,5mm precision of the laser dot detection concerning the x/y coordinate's (it concerns the whole target).
  - d) able to be used outdoor.
  - e) external perturbation protected (no reactions caused by incident light, which is different to the UIPM Signal).
  - f) competition mode must log all settings and shooting data. All data must be available after the competition for judges' purposes. All targets must have the same behaviour and performance (network management).
  - g) The shooting time starts when the target is hit by the first shot (registered shot, valid or not).
- iii) The dimensions of all scoring rings are measured from the outside edges (outside diameter) of the scoring rings (see figure 8).



Some more details are provided by the technical documents and Homologation documents. ("Technical Specifications Laser Shooting" and the current UIPM Homologation documents)

### 5.10.5 Indicators (Result Display Lights) (see Figure 7)

- i) Indicator Wavelength: Red colour must be 640nm and green colour 520nm. (+/- 20nm.) Indicators must be installed minimum 80cm up to the top of the target.
- ii) For "A" Category competitions, indicators must be clearly visible for the athletes and spectators and should be 55mm diameter with minimum of 120° viewing angle. Background of the indicators must be a contrasting colour. Distance between each red/green lamp must be about 40mm.
- iii) For all other competitions, different indicators can be used but the lights must be clearly visible for Athletes and coaches.
- iv) The electrical interface must comply with the UIPM specifications
- v) Indicators can be placed horizontally or vertically.

### Boxes

The LOC must provide boxes in the Shooting Range per station for athletes' use. These boxes are to be removed from the Shooting Range at the start and stored in a safe place until after competition.

## 5.11 LOC CONTROL DEVICES AND TOOLS

### 5.11.1 Control Material

Clothing control is made by observation, using a ruler if necessary.

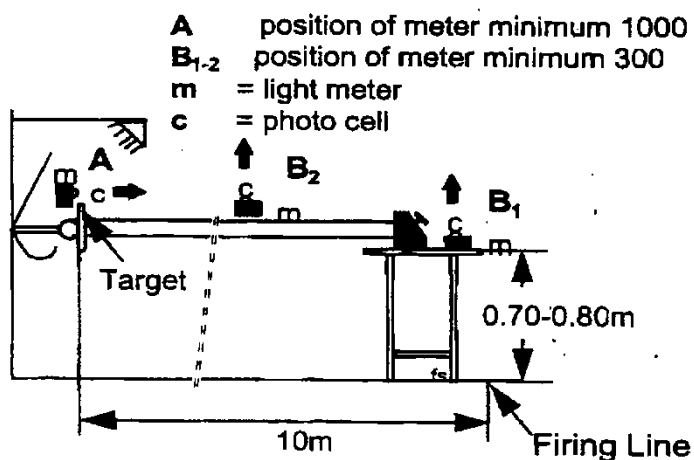
For the control of all kind of pistols (Part B, Art. 5.8) the LOC must have: box for dimensions, scale for the weight, ruler, square, angle scale and a system to register and mark the approved pistols.

For the laser pistols and laser cartridges, the LOC/ UIPM must also have instruments to check the laser beam - power, diameter and time - and the power of the battery.

### 5.11.2 Built Material and Tools

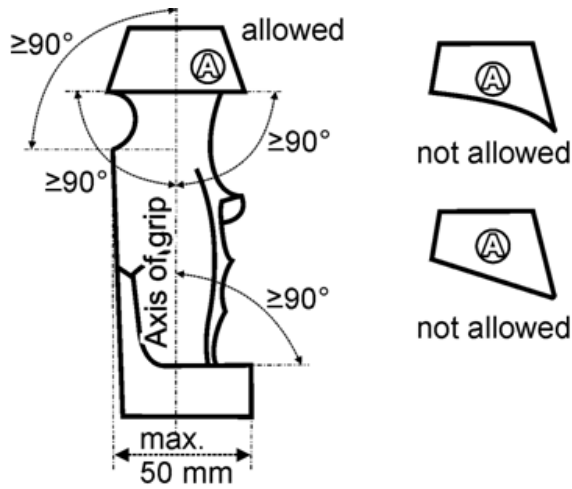
The LOC must have available material and tools to build, maintain and rebuild the FOP as described in Part B (5.3 The FOP and 5.4 – Other Equipment). This includes measuring tapes, rulers, measuring wheels, hammers, tools and equipment to repair the ground, barriers, poles or posts, tape, ink, paintbrush, plastic cones, and so on.

Figure 1 - Indoor or Night Range Light Requirements (in Lux)

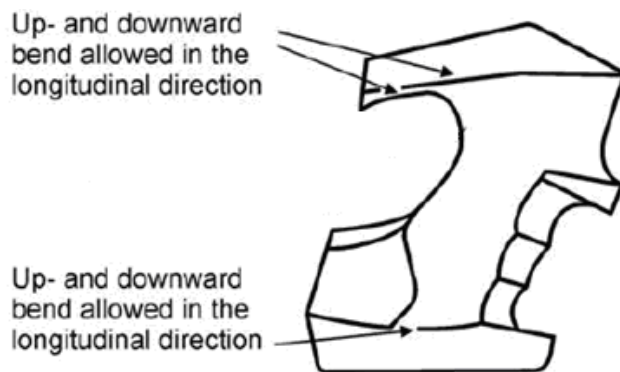




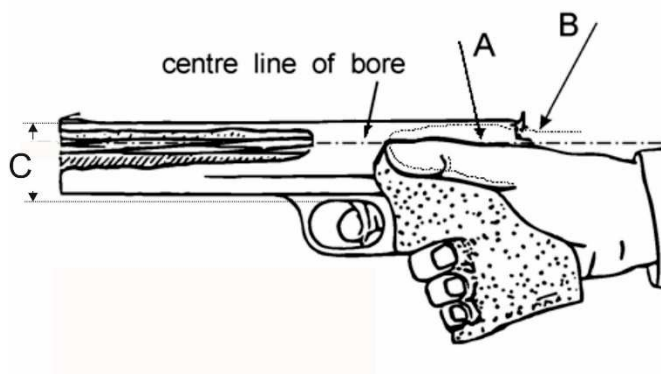
**Figure 2 – The Pistol Grip**



**Figure 3 – Bends in the Grip**



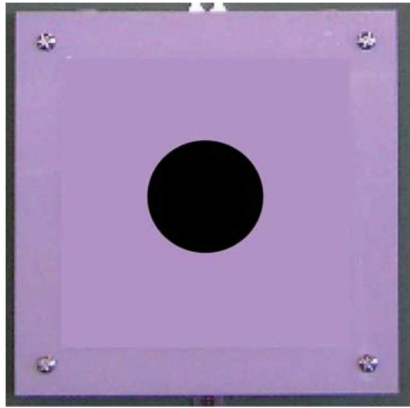
**Figure 4 – The Thumb in the Grip**



**Line A** ——— acceptable  
**Line B** - - - - - not acceptable  
**Area C**  
 Laser light emitting area



**Figure 5 – Laser Hit-Miss Target (examples)**

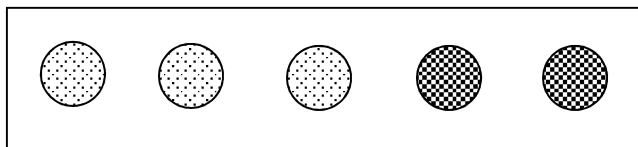
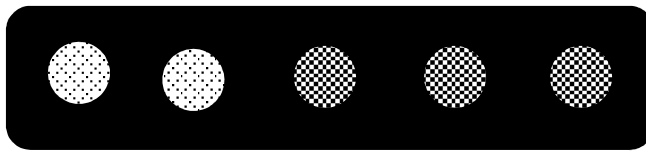


**Figure 6 – Laser Precision Target (examples)**

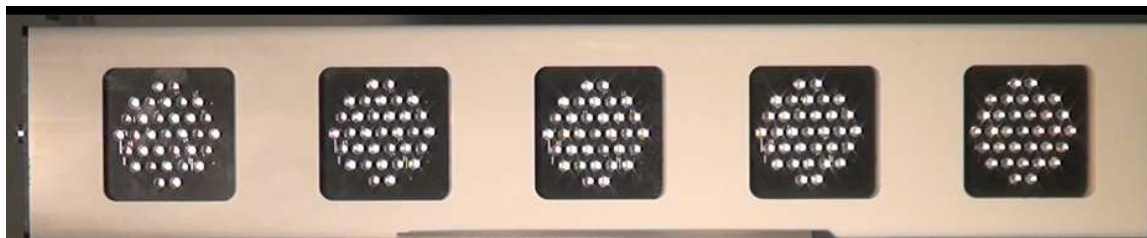




Figure 7 – Indicators (Result Display Lights) (examples)



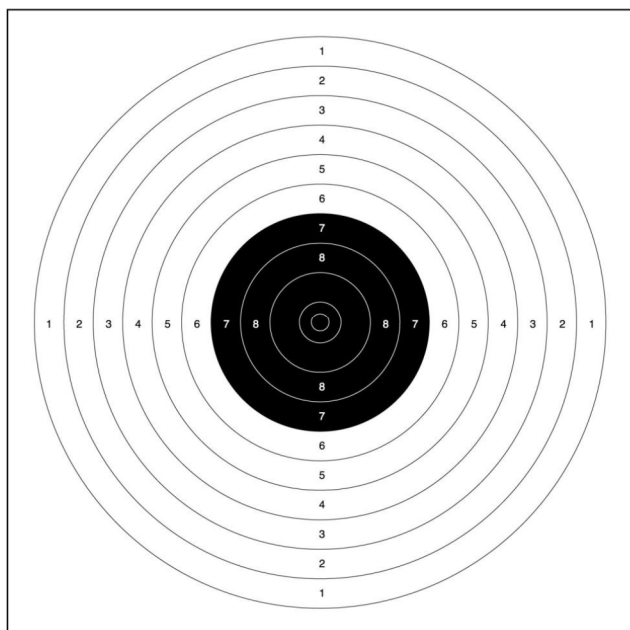
*(Black & white draw for impression B&W)*





**Figure 8 – The Precision Target and Hit-Miss Target**

<b>10 ring</b>	11.5 mm ( $\pm 0.1$ mm)	<b>5 ring</b>	91.5 mm ( $\pm 0.5$ mm)
<b>9 ring</b>	27.5 mm ( $\pm 0.1$ mm)	<b>4 ring</b>	107.5 mm ( $\pm 0.5$ mm)
<b>8 ring</b>	43.5 mm ( $\pm 0.2$ mm)	<b>3 ring</b>	123.5 mm ( $\pm 0.5$ mm)
<b>7 ring</b>	59.5 mm ( $\pm 0.5$ mm)	<b>2 ring</b>	139.5 mm ( $\pm 0.5$ mm)
<b>6 ring</b>	75.5 mm ( $\pm 0.5$ mm)	<b>1 ring</b>	155.5 mm ( $\pm 0.5$ mm)



**Central ten: 5.0 mm (+/- 0.1mm)**  
**Black from 7 to 10 rings = 59.5 mm**  
**Ring thickness: 0.1 mm to 0.2 mm**  
**Minimum visible size of target card 170 mm x 170 mm**



**Hit-Miss Target: Ring values are optional, ring drawings 2 - 6 and 8 - 10 are optional.**  
**Example:**

